

Heating Input : 40,000–100,000 BTU/h

Single-Stage, Single Speed,
Multi-Position Gas Furnace
80% AFUE



Contents

Nomenclature.....	2
Product Specifications.....	3
Dimensions	5
Airflow Data	8
Wiring Diagrams	11
Accessories	12
Minimum Filter Sizes	12

Standard Features

- Heavy-duty aluminized-steel, dual-diameter tubular heat exchanger
- Single-stage gas valve
- Durable Hot-surface igniter
- Quiet, single-speed draft induced
- Self-diagnostic control board
- Color-coded low-voltage terminals
- Multi-speed blower motor
- VHS8: High static airflow capability
- For installation in California’s South Coast Air Quality Management District (SCAQMD) only: This furnace does not meet the SCAQMD Rule 1111 14 ng/J NOx emission limit, and thus is subject to a mitigation fee of up to \$450. This furnace is not eligible for the SCAQMD Clean Air Furnace Rebate Program: www.CleanAirFurnaceRebate.com.
- AHRI Certified; ETL Listed AHRI Certified; ETL Listed

Cabinet Features

- Installation:
 - VMS8 - Upflow, horizontal left or right
 - VDS8 - Dedicated downflow
- Convenient left or right connection for gas and electrical service
- Heavy-gauge steel cabinet with durable baked-enamel finish
- Foil faced insulated heat exchanger



* Complete warranty details available from your local dealer or at www.elevateheatingandair.com

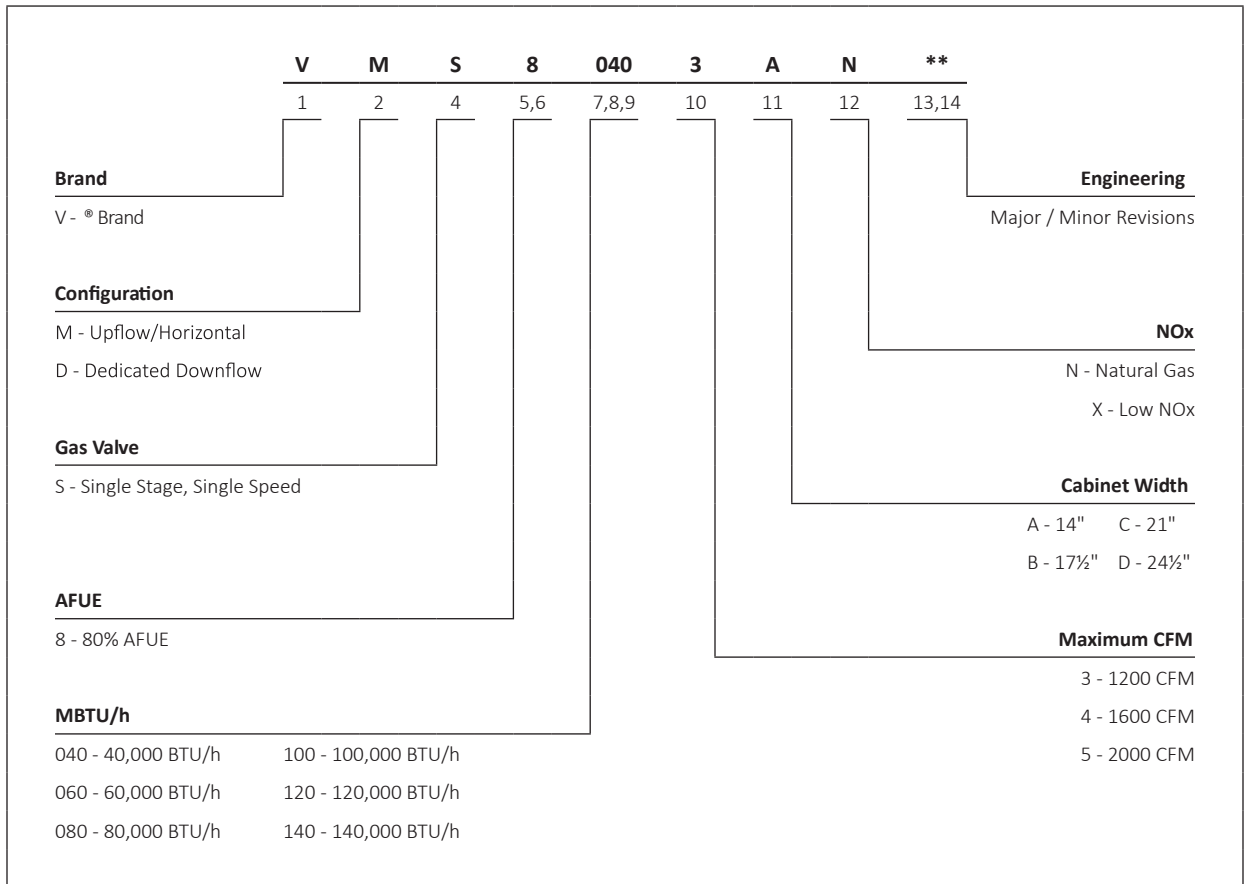

	VMS8 0403A*A	VMS8 0603A*A	VMS8 0604B*A	VMS8 0804B*A	VMS8 0805C*A	VMS8 1005C*A
Heating Capacity						
Input	40,000	60,000	60,000	80,000	80,000	100,000
Natural Gas Output	32,000	48,000	48,000	64,000	64,000	80,000
LP Gas Output	32,000	48,000	48,000	64,000	64,000	80,000
AFUE ¹	80	80	80	80	80	80
Available AC @ 0.5" ESP	3	3	4	4	5	5
Temperature Rise Range (°F)	25 - 55	20 - 50	20 - 50	35 - 65	35 - 65	35 - 65
Circulator Blower						
Size (D x W)	10" x 6"	10" x 6"	10" x 8"	10" x 8"	10" x 10"	10" x 10"
Horsepower @1075 RPM	⅓	⅓	½	½	½	½
Speed	4	4	4	4	4	4
Vent Diameter ²	4"	4"	4"	4"	4"	4"
No. of Burners	2	3	3	4	4	5
Electrical Data						
Min. Circuit Ampacity ³	4.8	4.8	8.8	8.8	8.8	8.8
Max. Overcurrent Device (amps) ⁴	15	15	15	15	15	15
Ship Weight (lbs)	84	88	98	106	114	118

All models available in California Low NOx-compliant versions

¹ DOE AFUE based upon Isolated Combustion System (ICS)

² Vent and combustion air diameters may vary depending upon vent length. Refer to the latest editions of the National Fuel Gas Code NFPA 54/ANSI Z223.1 (in the USA) and the Canada National Standard of Canada, CAN/CSA B149.1 and CAN/CSA B142.2 (in Canada).

³ Minimum Circuit Ampacity = (1.25 x Circulator Blower Amps) + ID Blower amps. Wire size should be determined in accordance with National Electrical Codes. Extensive wire runs will require larger wire sizes.

⁴ Maximum Overcurrent Protection Device refers to maximum recommended fuse or circuit breaker size. May use fuses or HACR-type circuit breakers of the same size as noted.

Notes

- All furnaces are manufactured for use on 115 VAC, 60 Hz, single-phase electrical supply.
- Gas Service Connection ½" FPT
- Important: Size fuses and wires properly and make electrical connections in accordance with the National Electrical Code and/or all existing local codes.

	VDS8 0603A*A	VDS8 0804B*A
Heating Capacity		
Input	60,000	80,000
Natural Gas Output	48,000	64,000
LP Gas Output	48,000	64,000
AFUE ¹	80	80
Available AC @ 0.5" ESP	3	4
Temperature Rise Range (°F)	30-60	35-65
Circulator Blower		
Size (D x W)	10" x 6"	10" x 8"
Horsepower @1075 RPM	1/3	1/2
Speed	4	4
Vent Diameter ²	4"	4"
No. of Burners	3	4
Electrical Data		
Min. Circuit Ampacity ³	4.8	8.8
Max. Overcurrent Device (amps) ⁴	15	15
Ship Weight (lbs)	92	105

¹ DOE AFUE based upon Isolated Combustion System (ICS)

² Vent and combustion air diameters may vary depending upon vent length. Refer to the latest editions of the National Fuel Gas Code NFPA 54/ANSI Z223.1 (in the USA) and the Canada National Standard of Canada, CAN/CSA B149.1 and CAN/CSA B142.2 (in Canada).

³ Minimum Circuit Ampacity = (1.25 x Circulator Blower Amps) + ID Blower amps. Wire size should be determined in accordance with National Electrical Codes. Extensive wire runs will require larger wire sizes.

⁴ Maximum Overcurrent Protection Device refers to maximum recommended fuse or circuit breaker size. May use fuses or HACR-type circuit breakers of the same size as noted.

Notes

- All furnaces are manufactured for use on 115 VAC, 60 Hz, single-phase electrical supply.
- Gas Service Connection ½" FPT
- Important: Size fuses and wires properly and make electrical connections in accordance with the National Electrical Code and/or all existing local codes.

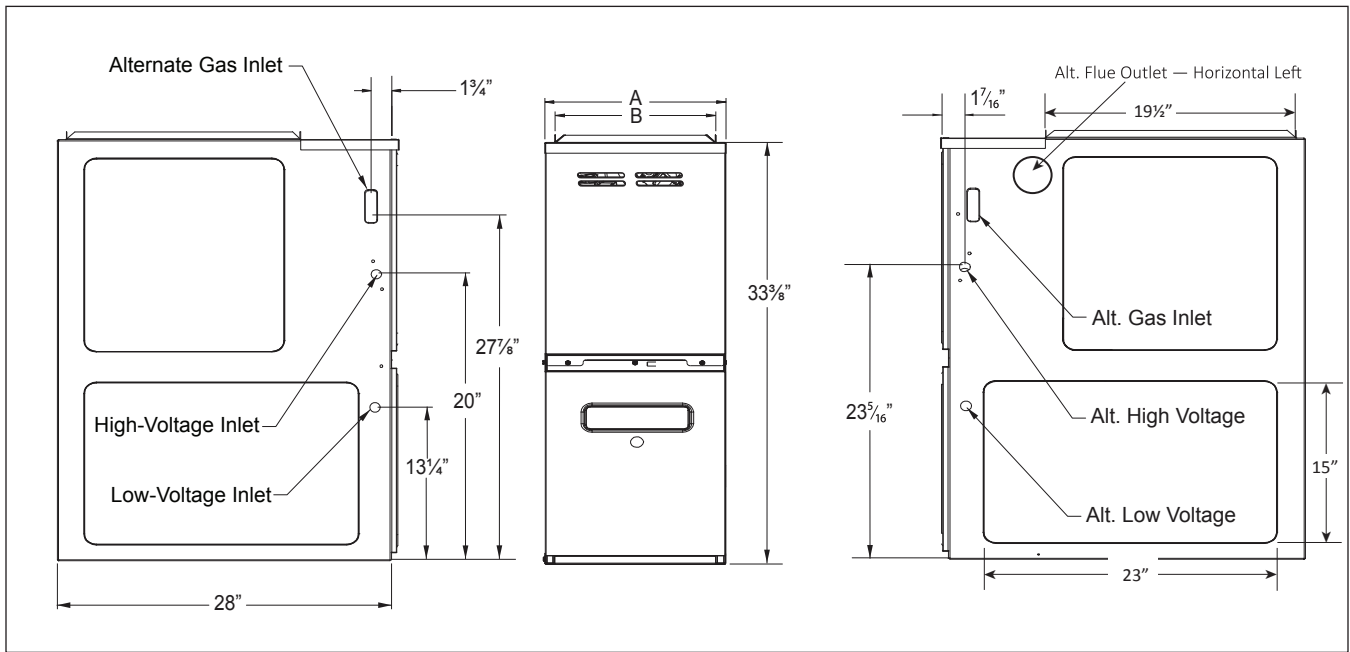

Model	A	B
VMS80403A**	14"	12 1/2"
VMS80603A**	14"	12 1/2"
VMS80604B**	17 1/2"	16"
VMS80804B**	17 1/2"	16"
VMS80805C**	21"	19 1/2"
VMS81005C**	21"	19 1/2"
VDS80603A**	14"	12 1/2"
VDS80804B**	17 1/2"	16"

Notes

- Line voltage wiring can enter through the right or left side of furnace. Low-voltage wiring can enter through the right or left side of furnace.
- Conversion kits for high-altitude (4500+ ft) natural gas operation are available. Contact your Goodman distributor or dealer for details.

Minimum Clearances to Combustible Materials

Sides	Rear	Front ¹	Vent ²		Top
			SW	B	
1"	0"	3"	6"	1"	1"

¹ 24" clearance for serviceability recommended.

² Single Wall Vent (SW) to be used only as a connector. Refer to the latest editions of the National Fuel Gas Code NFPA 54/ ANSI Z223.1 (in the USA) and the Canada National Standard of Canada, CAN/CSA B149.1 and CAN/CSA B142.2 (in Canada).

Note: VMS8 approved for line contact in the horizontal position.

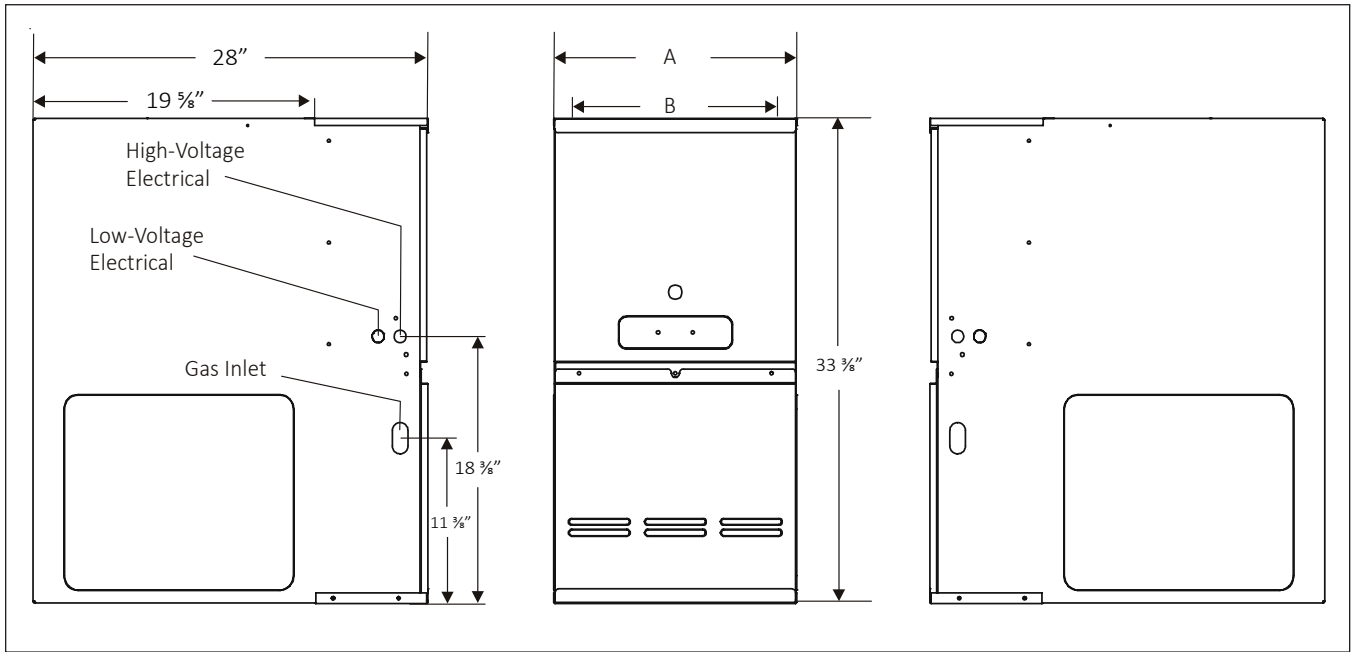

Model	A	B	Non-Combustible Floor Base
VDS80603A**	14"	12½"	SBT14
VDS80804B**	17½"	16"	SBT17

Notes

- Line voltage wiring can enter through the right or left side of furnace. Low-voltage wiring can enter through the right or left side of furnace.
- Conversion kits for high-altitude (4500+ ft) natural gas operation are available. Contact your Elevate distributor or dealer for details.

Minimum Clearances to Combustible Materials

Sides	Rear	Front ¹	Vent ²		Top
			SW	B	
1"	0"	3"	6"	1"	1"

¹ 24" clearance for serviceability recommended.

² Single Wall Vent (SW) to be used only as a connector. Refer to the latest editions of the National Fuel Gas Code NFPA 54/ ANSI Z223.1 (in the USA) and the Canada National Standard of Canada, CAN/CSA B149.1 and CAN/CSA B142.2 (in Canada).

Note: VMS8 approved for line contact in the horizontal position.

CFM & Temperature Rise vs. External Static Pressure

Model	Motor Speed	Tons AC ¹	External Static Pressure, (Inches Water Column)												
			0.1		0.2		0.3		0.4		0.5		0.6	0.7	0.8
			CFM	Rise	CFM	Rise	CFM	Rise	CFM	Rise	CFM	Rise	CFM	CFM	CFM
VMS8 0403A*A	High	3	1,521	---	1,466	---	1,414	---	1,373	---	1,298	---	1,243	1,164	1,075
	Med	2.5	1,160	26	1,160	26	1,132	26	1,121	26	1,082	27	1,042	997	925
	Med-Lo	2	961	31	955	31	948	31	932	32	913	33	882	821	803
	Low	1.5	781	38	785	38	781	38	773	38	761	32	745	716	668
VMS8 0603A*A	High	3	1,422	31	1,352	33	1,307	34	1,197	37	1,157	38	1,092	1,075	983
	Med	2.5	1,098	40	1,081	41	1,051	42	1,039	43	1,021	44	983	924	868
	Med-Lo	2	919	48	913	49	892	50	847	---	829	---	818	792	728
	Low	1.5	758	---	741	---	741	---	733	---	699	---	677	649	626
VMS8 0604B*A	High	4	2,134	21	2,100	21	2,042	22	1,975	23	1,883	24	1,786	1,700	1,601
	Med	3.5	1,668	27	1,663	27	1,656	27	1,645	27	1,616	28	1,549	1,492	1,391
	Med-Lo	3	1,419	31	1,426	31	1,426	31	1,432	31	1,419	31	1,378	1,328	1,261
	Low	2.5	1,134	39	1,145	39	1,166	38	1,171	38	1,160	38	1,144	1,111	1,071
VMS8 0804B*A	High	4	2,051	---	1,983	---	1,895	---	1,812	---	1,725	---	1,627	1,530	1,439
	Med	3.5	1,736	---	1,708	35	1,652	36	1,611	37	1,540	38	1,475	1,394	1,307
	Med-Lo	3	1,493	35	1,668	36	1,459	41	1,429	41	1,389	43	1,339	1,274	1,204
	Low	2.5	1,200	49	1,185	50	1,180	50	1,173	51	1,158	51	1,125	1,125	1,080
VMS8 0805C*A	High	5	2,290	---	2,229	---	2,155	---	2,047	---	1,960	---	1,837	1,712	1,584
	Med	4	1,852	---	1,820	---	1,777	---	1,719	---	1,641	36	1,567	1,469	1,382
	Med-Lo	3.5	1,615	37	1,592	37	1,556	38	1,516	39	1,470	40	1,405	1,346	1,235
	Low	3	1,290	46	1,285	46	1,265	47	1,235	48	1,214	49	1,174	1,044	904
VMS8 1005C*A	High	5	2,323	---	2,225	---	2,120	35	2,040	36	1,974	38	1,801	1,688	1,577
	Med	4	1,858	40	1,847	40	1,799	41	1,744	42	1,674	44	1,577	1,493	1,399
	Med-Lo	3.5	1,596	46	1,587	47	1,571	47	1,552	48	1,493	50	1,397	1,326	1,217
	Low	3	1,291	57	1,272	58	1,261	59	1,257	59	1,205	61	1,168	1,118	1,060

¹ at 0.5" ESP

Notes:

- CFM in chart is without filter(s). Filters do not ship with this furnace, but must be provided by the installer. If the furnace requires two return filters, this chart assumes both filters are installed.
- All furnaces ship as high-speed cooling and medium-speed heating. Installer must adjust blower cooling and heating speed as needed.
- For most jobs, about 400 CFM per ton when cooling is desirable.
- INSTALLATION IS TO BE ADJUSTED TO OBTAIN TEMPERATURE RISE WITHIN THE RANGE SPECIFIED ON THE RATING PLATE.
- This chart is for information only. For satisfactory operation, external static pressure must not exceed value shown on the rating plate.
- The dashed (---) areas indicate a temperature rise not recommended for this model.
- At higher altitudes, a properly derated unit will have approximately the same temperature rise at a particular CFM, while ESP at the CFM will be lower.

CFM & Temperature Rise vs. External Static Pressure

Model	Motor Speed	Tons AC ¹	External Static Pressure, (Inches Water Column)												
			0.1		0.2		0.3		0.4		0.5		0.6	0.7	0.8
			CFM	Rise	CFM	Rise	CFM	Rise	CFM	Rise	CFM	Rise	CFM	CFM	CFM
VDS8 0603A*A	High	3.0	1,290	34	1,236	36	1,194	37	1,166	38	1,176	38	1,166	1,108	1,029
	Med	2.5	1,139	39	1,090	41	1,035	43	1,063	42	1,063	42	1020	962	895
	Med-Lo	2.0	962	46	927	48	925	48	941	47	909	49	877	834	779
	Low	1.5	787	56	776	57	763	58	744	60	723	---	690	641	581
VDS8 0804B*A	High	4.0	2,128	---	2,063	---	2,001	---	1,927	---	1,824	---	1,726	1,628	1,529
	Med	3.5	1,840	---	1,788	---	1,745	---	1,689	35	1,625	36	1,550	1,470	1,364
	Med-Lo	3.0	1,602	37	1,558	38	1,543	38	1,493	40	1,455	41	1,402	1,328	1,239
	Low	2.5	1,277	46	1,252	47	1,244	48	1,229	48	1,214	49	1,179	1141	1079

¹ at 0.5" ESP**Notes**

- CFM in chart is without filter(s). Filters do not ship with this furnace, but must be provided by the installer. If the furnace requires two return filters, this chart assumes both filters are installed.
- All furnaces ship as high-speed cooling and medium-speed heating. Installer must adjust blower cooling and heating speed as needed.
- For most jobs, about 400 CFM per ton when cooling is desirable.
- INSTALLATION IS TO BE ADJUSTED TO OBTAIN TEMPERATURE RISE WITHIN THE RANGE SPECIFIED ON THE RATING PLATE.
- This chart is for information only. For satisfactory operation, external static pressure must not exceed value shown on the rating plate.
- The dashed (---) areas indicate a temperature rise not recommended for this model.
- At higher altitudes, a properly derated unit will have approximately the same temperature rise at a particular CFM, while ESP at the CFM will be lower.

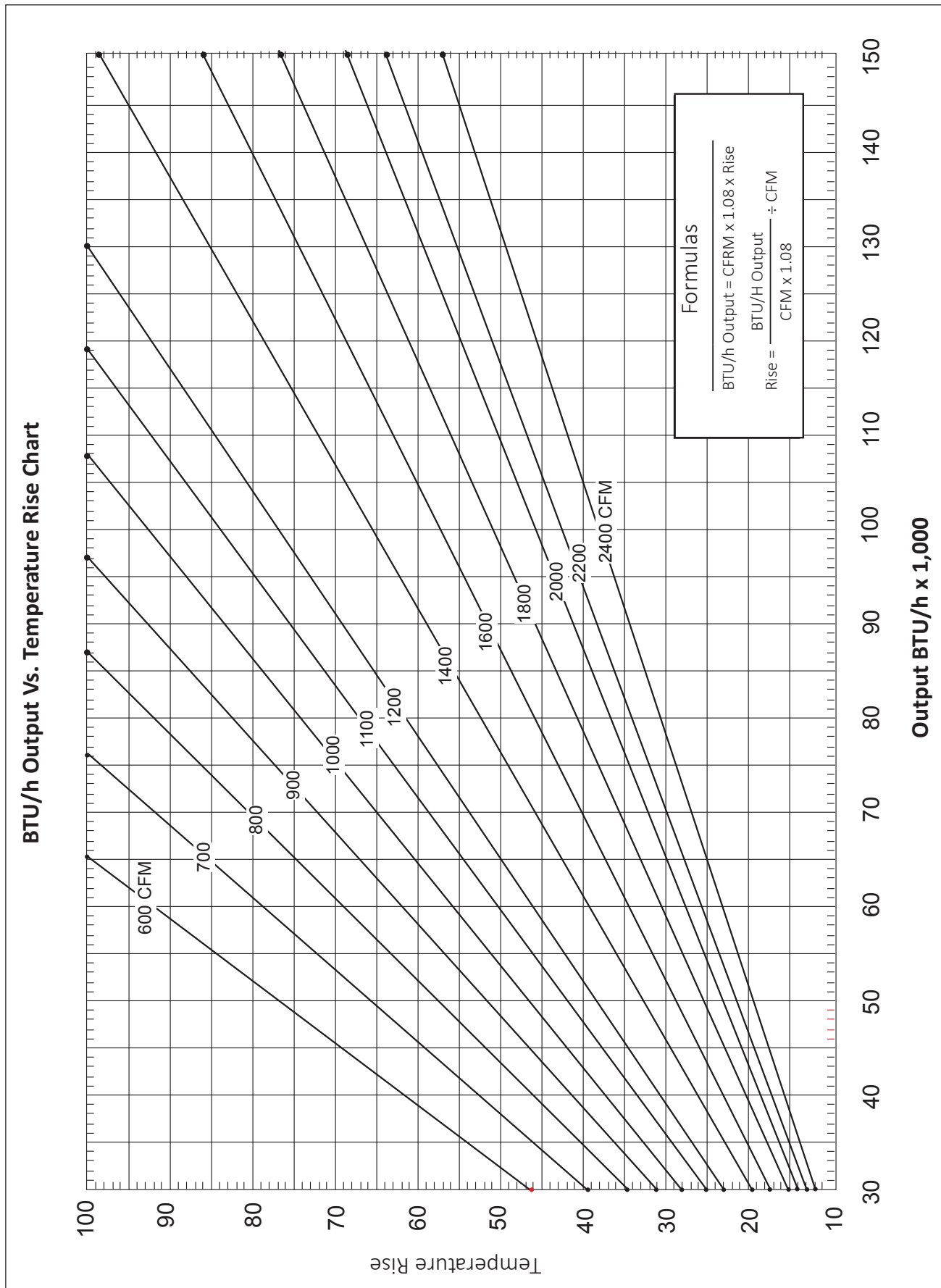

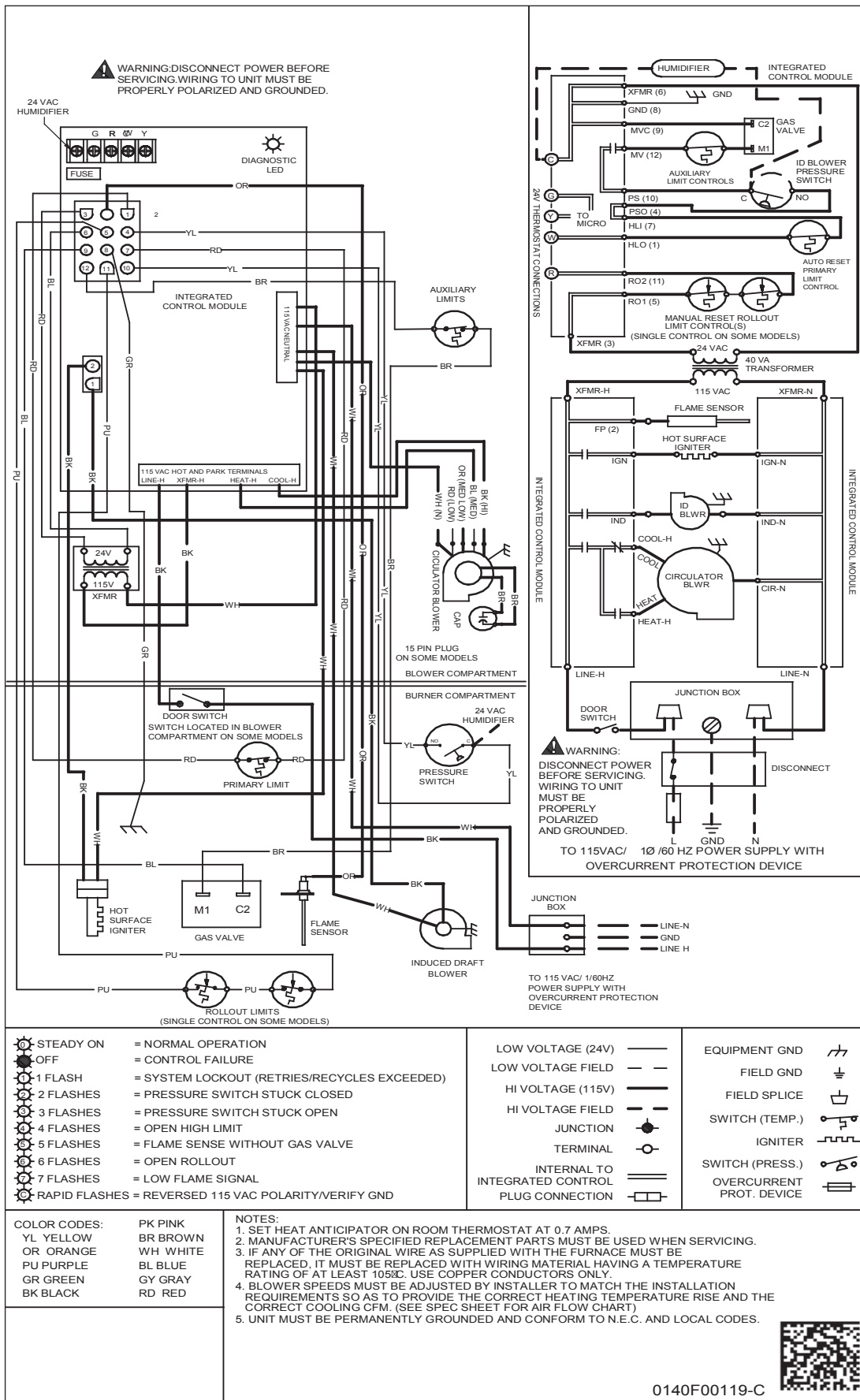

High Voltage: Disconnect all power before servicing or installing this unit. Multiple power sources may be present. Failure to do so may cause property damage, personal injury, or death.

Warning

Wiring is subject to change. Always refer to the wiring diagram on the unit for the most up-to-date wiring.

Model	Description
LPT-03 ¹	LP Conversion Kit
HANG20	High-Altitude Natural Gas Kit (4500+ ft)
AFE18-60A	Fossil Fuel Kit
MVK-01 ²	Masonry Vent Kit
TK-400	Twinning Kit

¹ White-Rodgers and Honeywell valves

² Upflow applications only

Downflow Sub-base for:

Model	Description	VDS8 0603A*B	VDS8 0804B*B
SBT14	14" Furnace	√	
SBT17	17½" Furnace		√
SBT21	21" Furnace		

Minimum Filter Sizes

Model #	VMS8 0403A*	VMS8 0603A*	VMS8 0604B*	VMS8 0804B*	VMS8 0805C*	VMS 81005C*
Filter Size (in ²)	(1) 16 x 25 (Side) or (1) 14 x 24 (Bottom)		(1) 16 x 25 (Side or Bottom)		(1) 16 x 25 (Side or Bottom) ¹	(2) 16 x 25 (Side) or (1) 20 x 25 (Bottom)

Model #	VDS8 0603A*	GDS8 0804B*
Filter Size (in ²)	(2) 10 x 20 or (1) 14 x 25 (Top Return)	(2) 14xX 20 or (1) 16 x 25 (Top Return)

Note: Other size filters of equal or greater surface area may be used; filters may also be centrally located.

¹ Use 2 - 16 x 25 filters on side returns or 20 x 25 filter on bottom return if furnace is connected to a cooling unit over 4 tons nominal capacity.